



Drain-Net Technologies
 PO Box 203
 Stanton, NJ 08885
 Phone: 908-236-0277
 Fax: 908-236-0278

Location: _____

Green Drain Floor Drain Trap Seal

Specification: Drain-Net Green Drain Series inline floor drain trap seal with UV resistant ABS plastic frame, silicon rubber sealing flapper and four flexible sealing ribs. Tested and certified to the ASSE 1072 Standard and listed with IAPMO and I.C.C. Specify connection size (2", 3", 3 1/2" or 4")

Function: Used in the outlet connections of floor drain bodies, or the inside of floor drain strainers to seal the opening to prevent odors, sewer gases, and insects from entering up through the floor drain grate. The four flexible silicone sealing ribs ensure easy installation into openings that have variations in size. The Green Drain will open to allow drainage and close when there is no water flow. Green Drain can be installed in lieu of a trap primer.

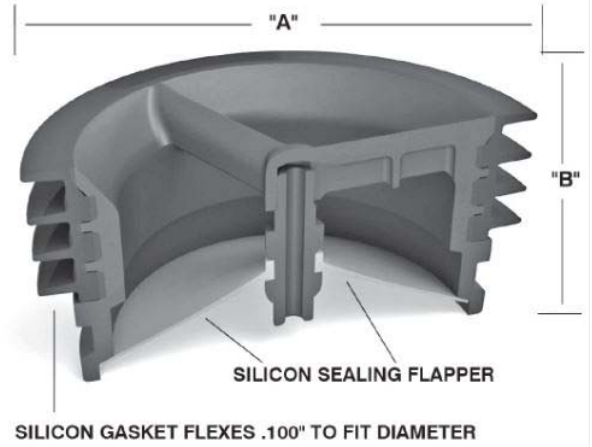

Model Number	Width (A)	Height (B)
GD102	2" (51)	2" (51)
GD103	3" (76)	2" (51)
GD1035	3 1/2" (89)	2" (51)
GD104	4" (102)	2" (51)

Drain-Net Green Drain prevents the following from entering through the top of floor drains:

- Odors and sewer gases
- Insects



Job Name: _____

Page No: _____

Page No: _____

Contract: _____

Schedule No: _____

Purchase Order #: _____

Have a question? Call: 908-236-0277 Toll Free: 1-844-564-9216 www.drain-tech.com

Drain-Net reserves the right to make changes in material and design without formal notice or obligation.